

BEDIENUNGSANLEITUNG ELEKTROLOKOMOTIVE BR 193 VECTRON

Instruction sheet for Electric Locomotive BR 193 Vectron
Manuale d'utilizzo per la locomotiva BR 193_Vectron

Wichtige Informationen sind in der Verpackung und in der Anleitung enthalten.
Bitte bewahren Sie diese auf.

21614 Gleichstrom DC PluX22
0-12 V

Taste / Chiave Key / Touches	Funktion / Funzione / Function / Fonctions			
F0	Spitzenlicht	Luce superiore	Head lights	Lumière du haut
F1*	Motor	Motore	Sound	Bruit moteur
F2	Horn hoch	Tromba suono alto	High Tone Horn	Klaxon
F3	Horn tief	Tromb suono di profondità	Low Tone Horn	Klaxon
F4*	Zugzielanzeige	Visualizzazione della destinazione dei treni	Train destination display	Affichage de la destination d'un train
F5	Lokführergruß	Saluto del macchinista	Engineer's Greeting	Salut chauffeur de train
F6	Pantograph	Pantografo	Pantograph	Pantographe
F7	Batterie Hauptschalter	Interuttore principale della batteria	Battery Main Switch	Interrupteurs principaux de la batterie
F8	Rangiergang	Manovra	Switching Gear	Vitesse de manœuvres
F9	Tür	Porta	Door	Porte
F10	Maschinenraumtür	Porta della sala macchine	Engine Room Door	Porte de la salle des machines
F11	Fenster	Finestra	Window	Fenêtre
F12	Druckluft ablassen	Scarico aria compressa	Air Valve Release	L'air comprimé laissé hors
F13	Kuppeln	Aggancio	Coupling	Accouplement de la rame
F14	Bahnhofsdurchsage #1	Annuncio stazione n. 1	Station Announcement 1	Annonces de la station
F15	Bahnhofsdurchsage #2	Annuncio stazione n. 2	Station Announcement 2	Annonces de la station
F16	Bahnhofsdurchsage #3	Annuncio stazione n. 3	Station Announcement 3	Annonces de la station
F17	Schaffnerpfeiff	Fischio capo stazione	Conductor's Whistle	Signal des conducteurs
F18	Kompressor	Compressore	Compressor	Compresseur
F19	Sprachumstellung (Deutsch <-> Italienisch)	Cambio di lingua (tedesco <-> italiano)	Language change (German <-> Italian)	Changement de langue (allemand <-> italien)
F20	Sanden	Sabbia	Sanding	Sablère
F21	Bremsprüfung	Prova dei freni	Break Test	Essai de freinage
F22	Kurvenquietschen	Stridio in curva	Curve Squeal	Sifflement en courbes
F23	Schienenstöße	Giunti ferroviari	Clickety-Clack	Bruit des joints de rails
F24	Zugbeleuchtung: Lok zieht	Illuminazione del treno: Locomotiva in traino	Train Lighting: Engine pulling	Éclairage des trains: la locomotive tire
F25	Zugbeleuchtung: Lok schiebt	Illuminazione del treno: Locomotiva al spinta	Train Lighting: Engine pushing	Éclairage du train: la locomotive pousse
F26	Lautstärkeregelung	Controllo del volume	Volume Regulator	Réglage du volume
F27	Ton aus	Disattiva Audio	Mute	Tonalité désactivée

* abhängig von Version / * a seconda della versione / * depending on version / * variable selon la version

Notizen:

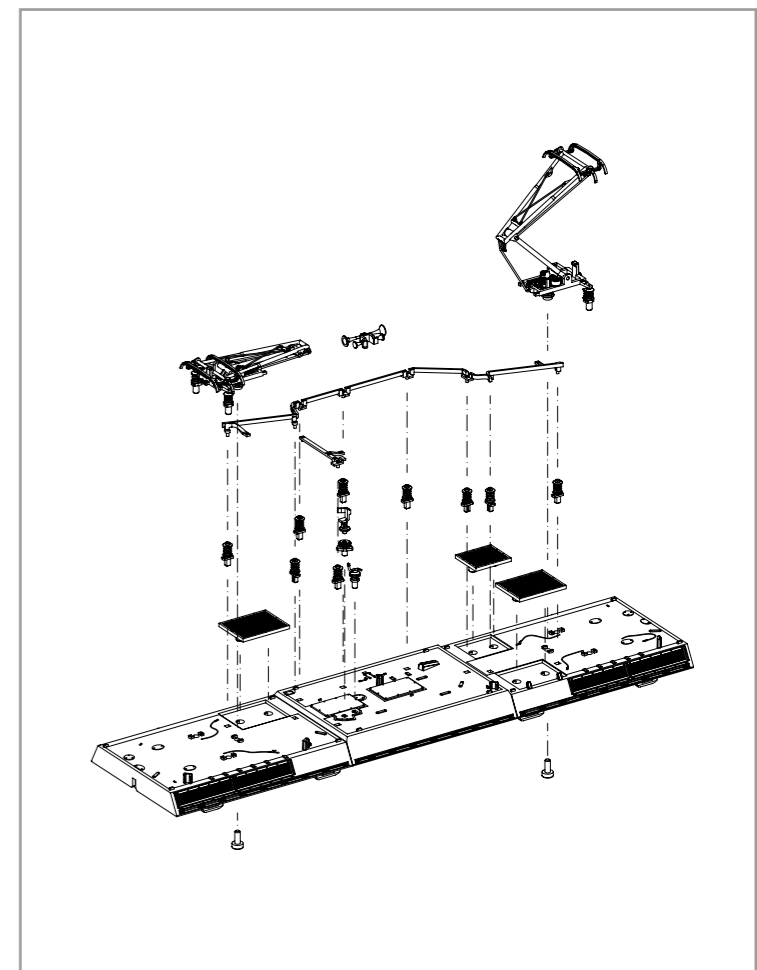
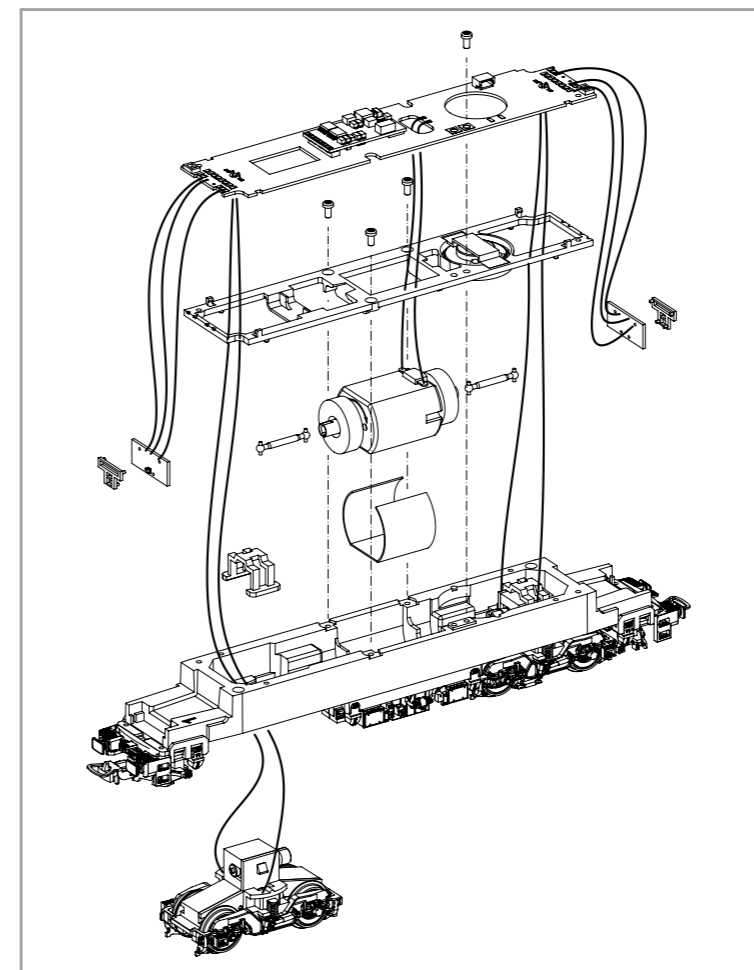
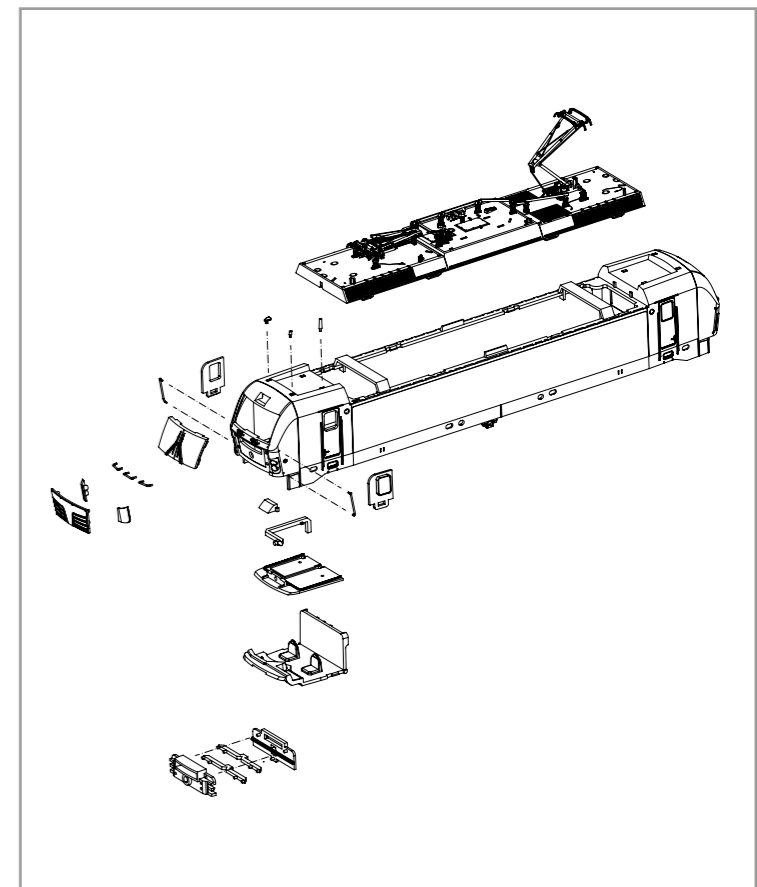
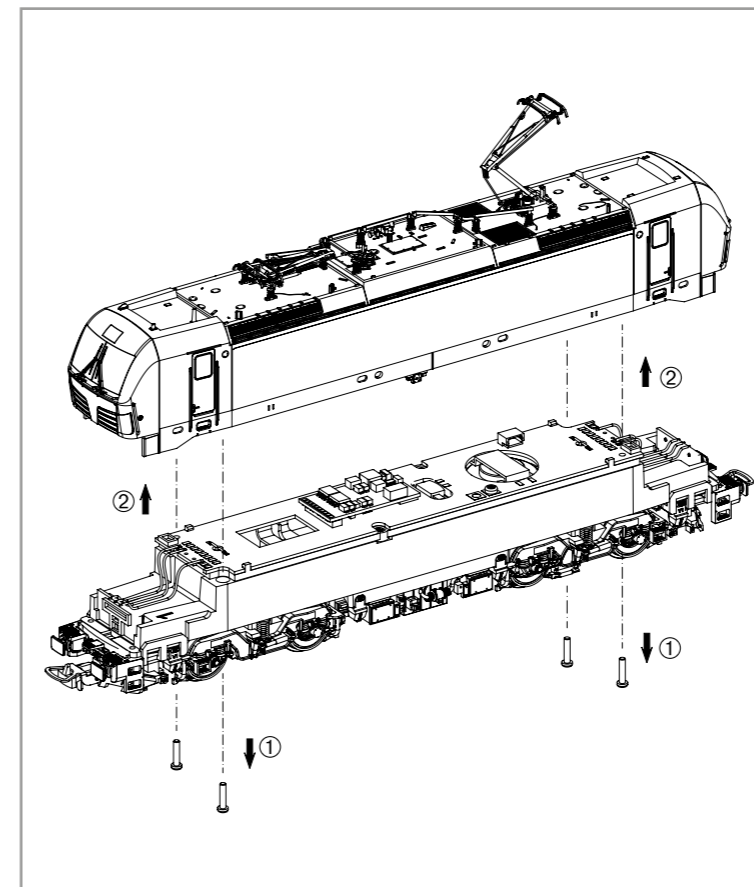

ERSATZTEILE ELEKTROLOKOMOTIVE BR 193 VECTRON

Spare parts for Electric Locomotive BR 193 Vectron / Parti di ricambio BR 193_Vectron

Bei Ersatzteilanforderung bitte immer die vollständige Ersatzteil-Nr. angeben • Please order the wanted spare part with the complete spare part item number.

#56544
PSD XP 5.1 Sound

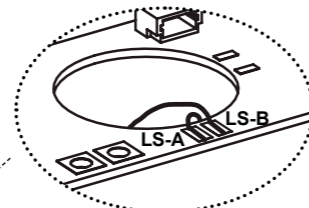

Kabel von Lautsprecher auf Leiterplatte anlöten! /
Solder cables of speakers on mainboard on! /
Souder les câbles du haut parleur au circuit imprimé /
Saldare il cavo dell'altoparlante sul circuito stampato

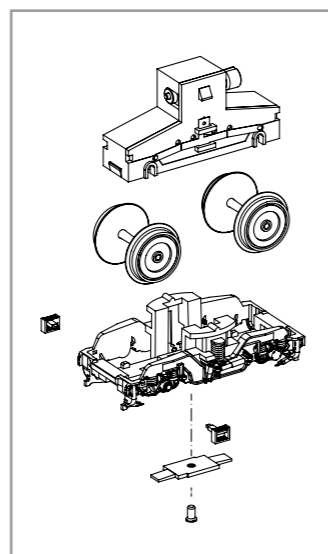
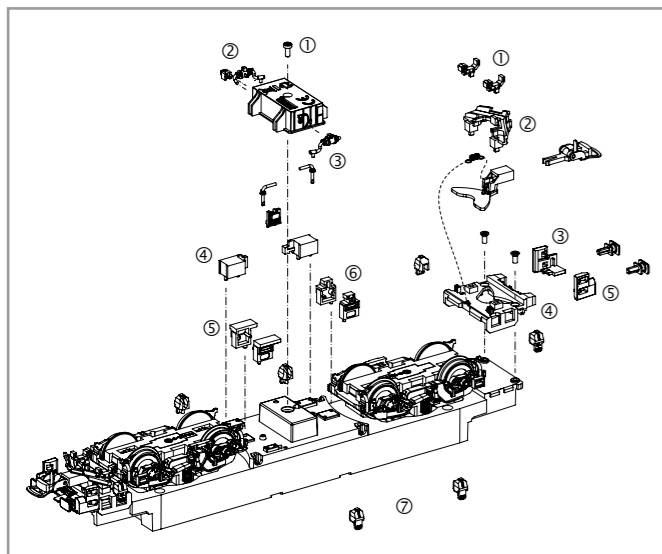
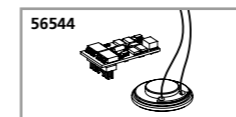
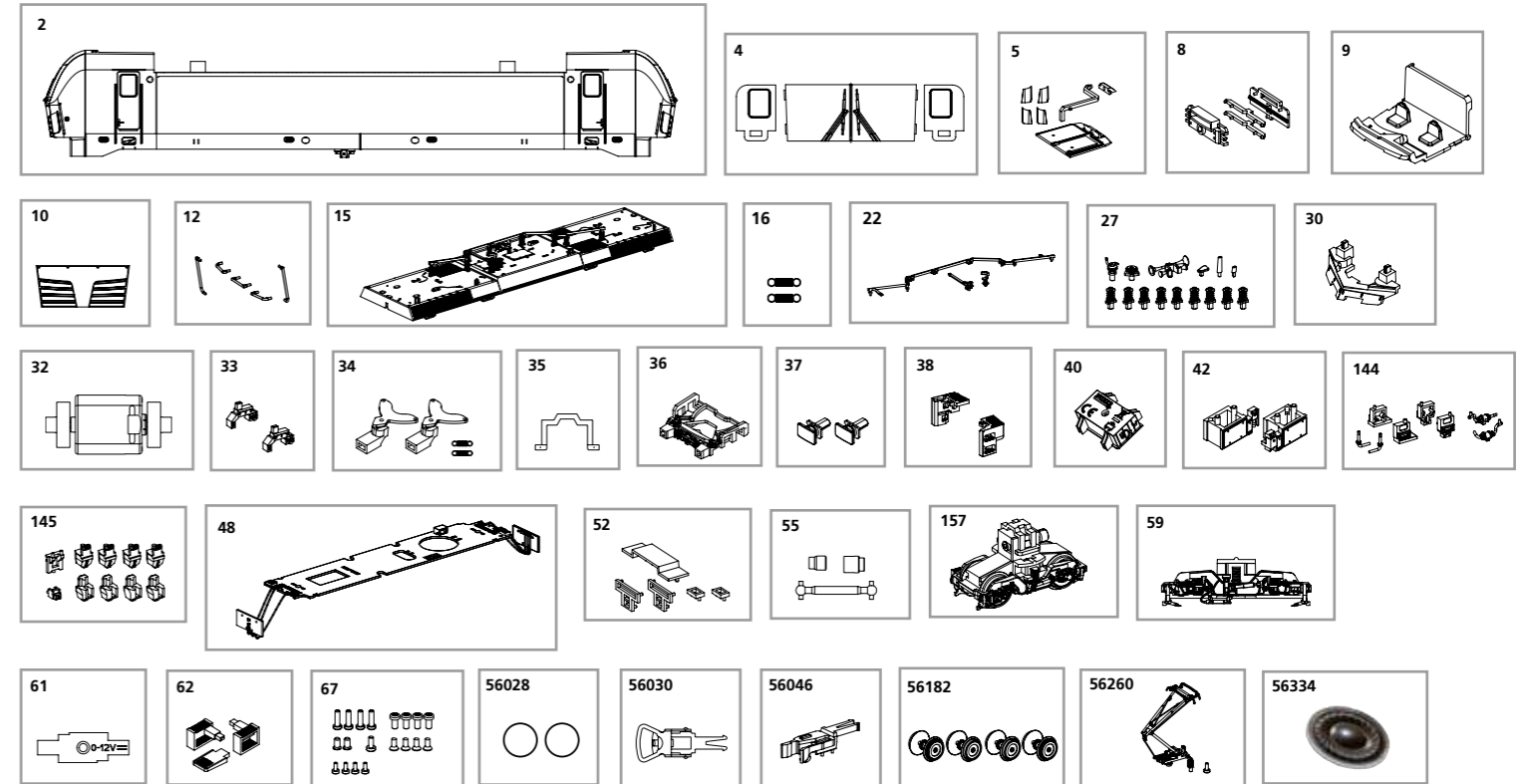
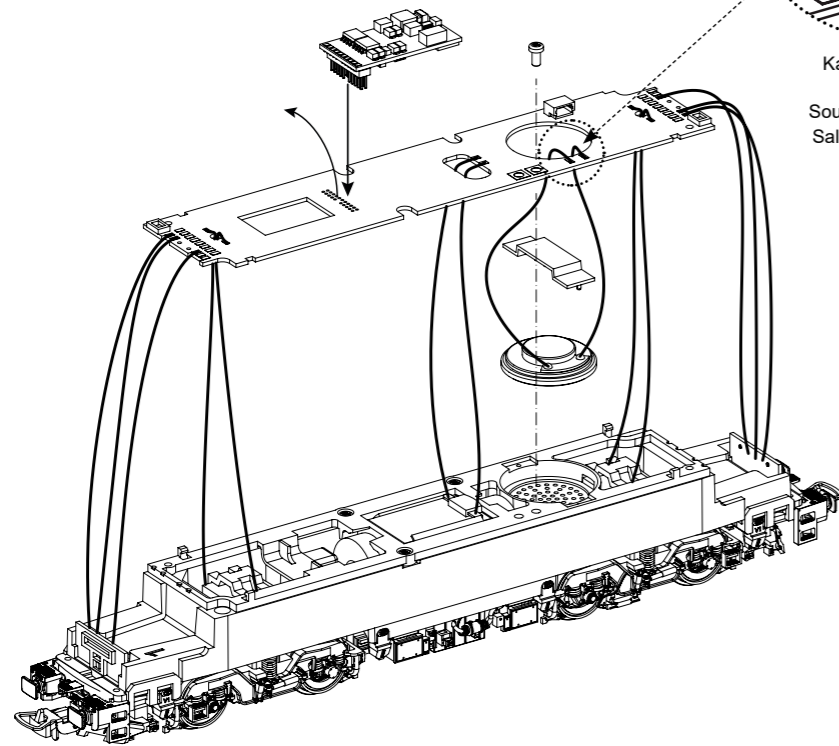

Bezeichnung / Description	ET-Nr. / spare part N°	PG*
Gehäuse, dekoriert (mit Fenster + Lichteinsätzen) / Body, decorated (with window + light inserts)	21613-02	13
Fenster / Windows	59970-04	8
Leuchstab oben + Scheinwerferensätze / Transfer light bar roof + headlight inserts	59971-05	9
Leuchstab unten mit Abdeckung / Light bar with cover	59970-08	7
Führerstand / Driver cab	59970-09	7
Frontklappe / Flap front	21613-10	7
Handstangen (5-tlg.) / Handrails (set of 5)	59971-12	9
Dach mit Lüftergitter / Roof with Ventilation plate	59598-15	11
Feder für Deichsel (2 Stck.) / Spring for drawbar (set of 2)	59900-16	5
Hochspannungskabel / High-voltage cable	59598-22	7
Isolatoren, Hupe, Antennen / Insulators, Horn, Antenna	97717-27	9
Schienenräumer / Cow catcher	59189-30	7
Motor komplett / Motor complete	59900-32	12
Ansteckteil Schienenräumer (2 Stck.) / Cow catcher part (set of 2)	59971-33	7
Kupplungsdeichsel (2 Stck.) mit Feder (2 Stck.) / Drawbar (set of 2) with spring (set of 2)	59970-34	7
Getriebeklammer / Gear box clip	59900-35	6
Pufferbohle / Buffer base	59970-36	7
Puffer (2 Stck.) / Buffer (set of 2)	59970-37	6
Schürze rechts, links / Step right, left	59971-38	7
Transformator / Transformator box	21613-40	7
Batteriefach Elektro (2-tlg.) / Battery electric (set of 2)	59596-42	8
Anbauteile 1 / Attaching parts 1	97760-144	7
Anbauteile 2 / Attaching parts 2	21613-145	8
Hauptplatine mit Beleuchtungsplatine und Kabel / Main board with Light-boards and wires	59970-48	15
Lichtmasken / LED cover	59970-52	7
Kardanwelle + Buchsen / Ball shaft + bushes	59970-55	7
Getriebe, komplett / Gearbox, complete	59183-157	12
Drehgestell mit Treppen / Bogie with steps	59970-59	9
Drehgestellabdeckung / Bogie bottom cover	59970-61	7
Treppen / Steps	59970-62	6
Schraubenset (19-tlg.) / Screws (set of 19)	59970-67	7

Bezeichnung / Description	ET-Nr. / spare part N°	PG*
ET aus unserem Standard-Programm / Spare parts standard range		
Haftreifen (10 Stck.) / Friction tyres (set of 10)		
Kupplung, vollst. (2 Stck.) / Coupling, complete (set of 2)	56030	
HO PIKO Kurzkupplung (4 Stück) / HO PIKO short Coupling (set of 4)	56046	
Radsätze Set (4 Stck.) / Wheelset (set of 4)	56182	
Stromabnehmer SBB / Pantograph	56260	
Ersatzlautsprecher / Replacement loudspeaker	56334	
PIKO SmartDecoder XP 5.1 Sound / PIKO SmartDecoder XP 5.1 Sound	56544	

*Preisgruppe *price category