

Haftreifenwechsel
Change the Traction Tyres
Remplacer bandages
更换胶胎

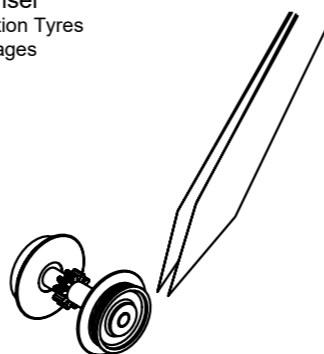

PIKO Art.-Nr.:
#56301 Lok-Öl (50 ml)
#56301 Loco-Oil / #56301 比高机油
#56300 Lok-Öler mit Feindosierung
#56300 Precision engine oiler w fine dosage /
#56300 比高机油

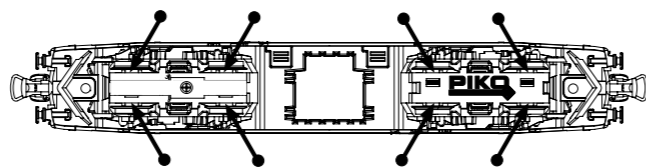
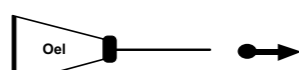

Ölen Sie bei häufigem Fahrbetrieb die Achslager mit einem Tropfen harz- und säurefreiem Nähmaschinenöl! Wir empfehlen, die Lok ca. 25 min je Fahrtrichtung ohne Belastung einlaufen zu lassen, damit das Modell einen optimalen Rundlauf und eine gute Zugkraft erhält. Bitte beachten Sie, daß der einwandfreie Lauf des Modells nur auf sauberen Schienen gewährleistet ist.

En cas d'utilisation intense, graisse les essieux avec une goutte d'huile pour machine à coudre exempte d'acide ou de résine! Afin d'optimiser les caractéristiques de traction et de fonctionnement, il est recommandé de faire rouler la locomotive seule, sans chargement, 25 minutes dans chaque sens. Pour un bon fonctionnement, il est essentiel que la voie soit propre.

If used frequently, oil the wheelsets with a drop of non-resinous, acid-free sewing machine oil! In order to achieve the best possible running and traction properties, it is advisable to run the locomotive in for 25 minutes forwards and 25 minutes in reverse without load. Clean rails are essential for good performance.

Se usate frequentemente l'olio, per il set delle ruote, mettete una goccia di olio, quello utilizzato nella macchina da cucire.

Si está sometida a un uso intensivo, engrase los ejes con una gota de aceite de maquina no acido.

如果经常使用，可以在车轮上加上不含树脂、非酸性机油！我们建议，让此火车不断转换方向地行驶大约25分钟，以便让它保持最优的回转及良好的牵引力。请注意，只有在清洁的轨道上才能保证此模型行驶畅顺。

Breng, bij regelmatig gebruik, op de wagenassen een druppeltje hars- en zuurvrije naaimachineolie aan!

W przypadku częstego używania należy wpuścić kroplę oleju maszynowego nie zawierającego żywicy i kwasu!

После длительной эксплуатации локомотива следует смазать подшипники двигателя и передаточного механизма, используя для этой цели в небольшом количестве техническое масло.

Prosím mazejte při častější jízdě sady kol kapkou oleje na šici stroje!

D Hinweis:
Sicherheitshinweise in weiteren Sprachen finden Sie unter: www.piko-shop.de

GB Please note:
Safety instructions in other languages, please see: www.piko-shop.de

F Conseil:
Des consignes de sécurité dans d'autres langues peuvent être trouvées sur: www.piko-shop.de

NL Attentie:
Veiligheidsinstructies in andere talen zijn te vinden op: www.piko-shop.de

IT Nota:
Le istruzioni di sicurezza in altre lingue sono disponibili su: www.piko-shop.de

E Aviso:
Las instrucciones de seguridad en otros idiomas se pueden encontrar en: www.piko-shop.de

PL Uwaga:
Wskazówki bezpieczeństwa w innych językach są dostępne pod adresem: www.piko-shop.de

RU Намек:
Инструкции по безопасности на других языках можно найти на: www.piko-shop.de

CN 提示:
如需其他语言的安全须知请访问: www.piko-shop.de

CZ Upozornění:
Bezpečnostní pokyny v jiných jazycích naleznete na adrese: www.piko-shop.de



PIKO Spielwaren GmbH • Lutherstraße 30 • 96515 Sonneberg • GERMANY
Tel. +49 (3675) 8972 - 55 (dienstags und donnerstags von 16 - 18 Uhr)

57926-90-7001

Achtung:
Sicherheitshinweise in weiteren Sprachen finden Sie unter: www.piko-shop.de

Attention:
Safety instructions in other languages, please see: www.piko-shop.de

BEDIENUNGSANLEITUNG ELEKTROLOK TAURUS

Instructions for use electrical loco Taurus · Manuel d'utilisation pour locomotive électrique Taurus · Manuale d'utilizzo per la locomotiva Taurus · Manual de usuario de la locomotora Taurus · 电动火车头桃乐丝的使用说明 · Gebruiksaanwijzing locomotief Taurus · Instrukcja obsługi lokomotywy elektryczny · Инструкция по эксплуатации. Электровоз. · Návod k použití elektrické lokomotivy

NEM 652

57926 Gleichstrom DC 0-12 V ---

包装及说明书内包含重要信息，请保留备用

Für digitalen Betrieb des Modells ist ein geeigneter Decoder nachzurüsten!

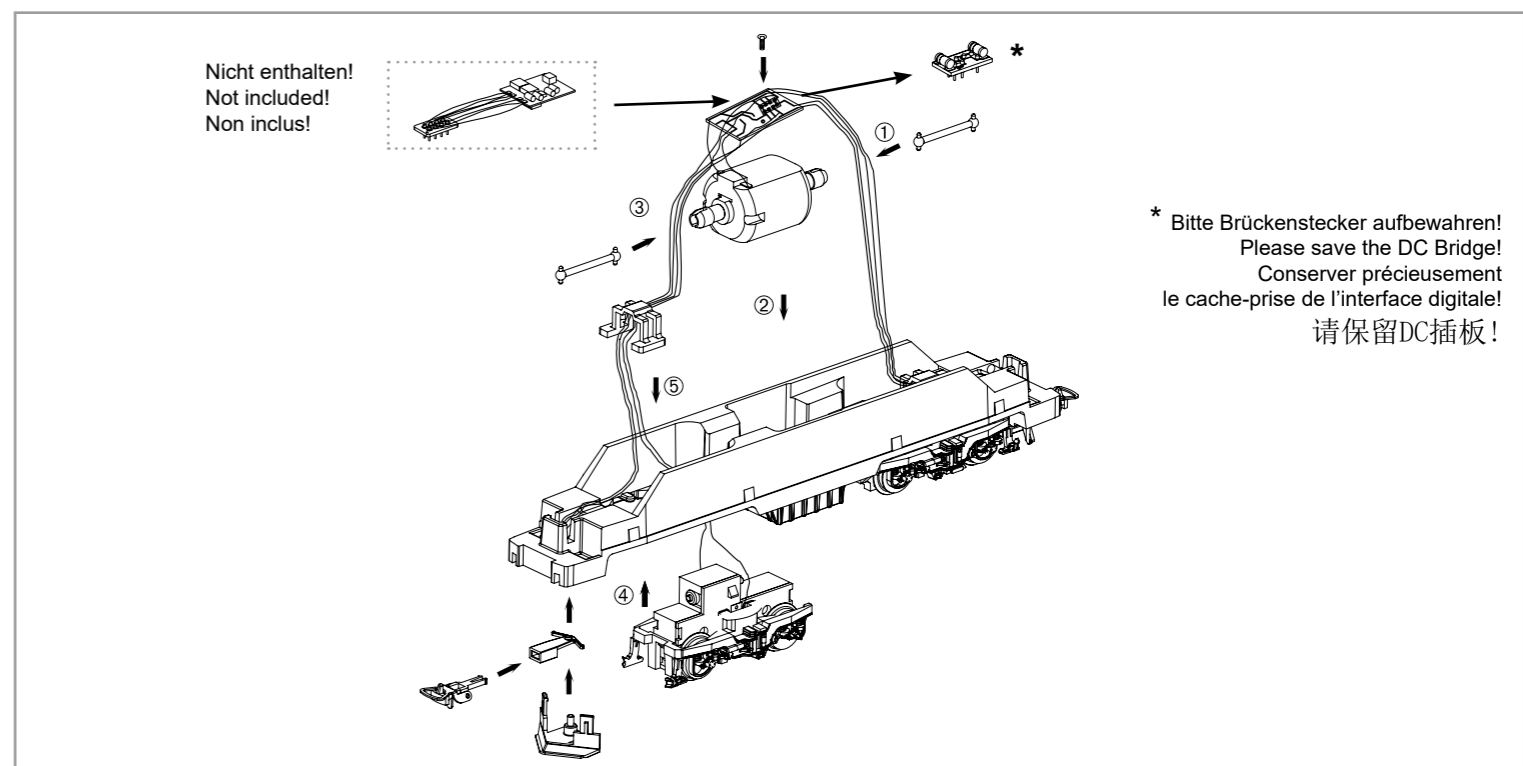
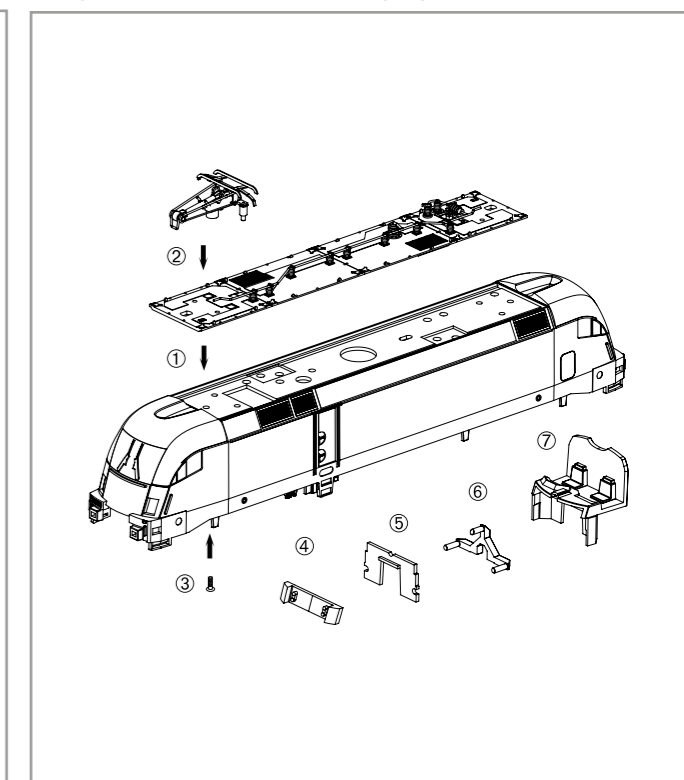
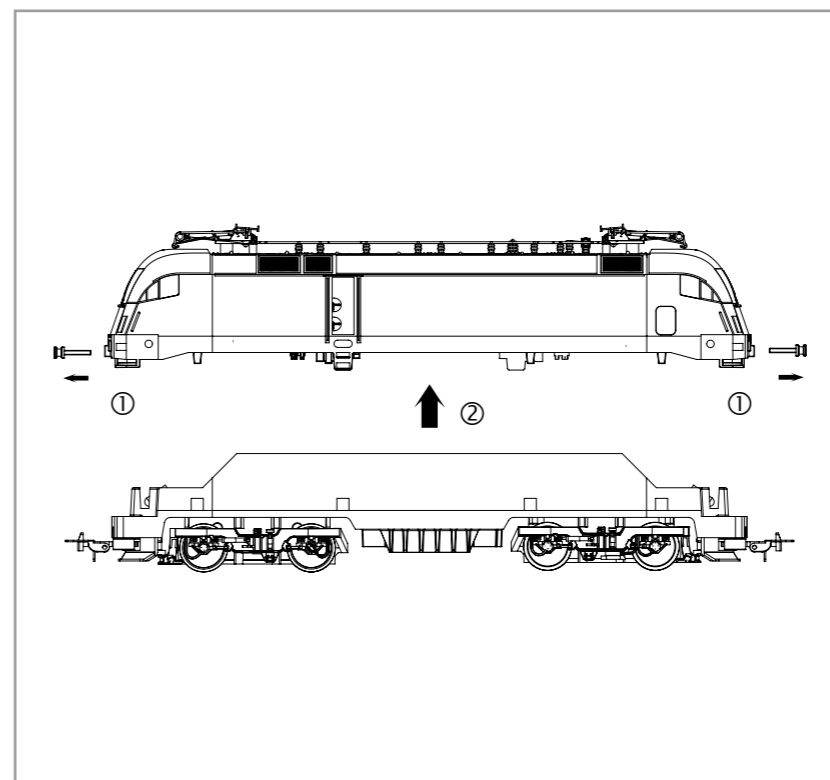

Hinweis:
Die Funk-Entstörung der Anlage ist mit dieser Lokomotive sichergestellt, wenn der üblicherweise im Glets-Anschlussstück eingebaute Kondensator eine Kapazität von mindestens 680 Nanofarad aufweist.

Note:
With this locomotive interference will not occur if the condenser normally fitted in the track connection section has a minimum capacity of 680 nano farads.

Conseil:
Cette locomotive est équipée d'un filtre anti-parasite. Un condensateur placé habituellement dans les joints des rails présente une capacité minimale de 680 nF.

Nota:
Con questa locomotiva Interferenze non occorre, se il condensatore normalmente montato nella traccia della sezione de connessione, ha un minimo di capacità di 680 nF.

Nota:
El sistema antiparasitario de la instalación está asegurado con esta locomotora si se utiliza, como es habitual, un tramo de vía de conexión con un condensador de como mínimo 680 nanofarados.

仅限于车：如果安装在轨道连接器部分的电容器有至少680nF，则车头不会发生电磁干扰。

Aanwijzing:
De ontstoring van jouw modelspoorweg is bij het gebruik van deze locomotief gegarandeerd, wanneer de normaal gesproken in het railsaansluitstuk ingebouwde condensator een capaciteit van minimaal 680 nanofarad heeft.

Wskazówka:
Ochrona przeciwzakłócenia urządzeń elektronicznych jest zapewniona w tej lokomotywie o ile kondensator wbudowany w część doprowadzającą prąd ma pojemność co najmniej 680 nF.

Обратите внимание:
Для подавления радиопомех от работающего электродвигателя, в соот-ветствии с еждународным законодательством, все модели PIKO оснащены специальным конденсатором.

Upozornění:
Odrušení Vašeho kolejistě je s touto lokomotivou zajištěno, pokud má obvykle do kolejového nástavce zabudovaný kondensátor kapacitu minimálně 680 Nanofaradů.

ERSATZTEILE TAURUS

Spare parts · Pièces détachées · Parti di ricambio · Repuestos · 配件 · Reserveonderdelen · Części zamienne · Запасные части · Náhradní díly

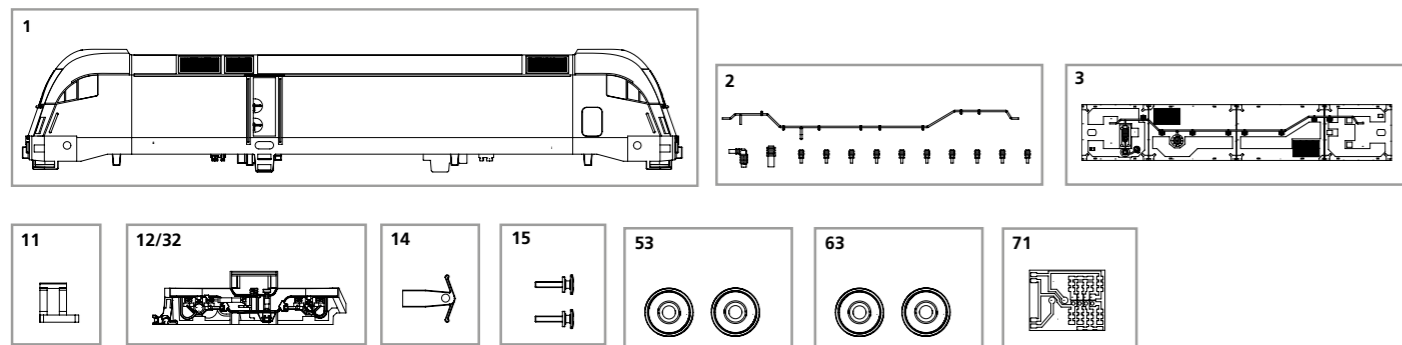

ET-Nr.	Bezeichnung:	Description:	Désignation:	Descrizione:	Descripción:	PG*																																																								
57926-01	Gehäuse, bedruckt + Fenster	Body, with printed windows	Boîtier, décoré avec fenêtre	Carrozzeria verniciata con finestre	Carcasa decorada + ventana	13																																																								
57410-02	Isolatoren / Dachleitungen	Insulators / Roof lines	Isolateurs / caténaire	Isolatori/condotti sul tetto	Aislantes / conductores del techo	8																																																								
57922-03	Dach, vollständig	Roof, complete	Toit, complet	Tetto completo	Techo completo	9																																																								
57410-05	Lichtleiter	Conductors	Câble en fibre optique	Condutture	Conductor de luz	6																																																								
57410-06	Inneneinrichtung	Interior fittings	Aménagement intérieur	Accessori interni	Decoración interior	7																																																								
57410-07	Schiennräumer	Snow plough	Chasse-neige	Scacciasassi	Limpiavías	7																																																								
57410-08	Motor, komplett	Motor, complete	Engrenage, complet	Motore completo	Motor completo	12																																																								
57410-09	Kardantrieb, 3-tlg.	Cardan shafts+universal joints	Cardan, 3 parties	Alberto con giunto cardanino e boccole	Eje cardán + cojinetes	7																																																								
57410-11	Klammer	Clip	Clip de sûreté	Clip	Clip	6																																																								
57410-12	Drehgestellblende	Bogie valance	Capot pour bogie	Copertura per carrelli	Tapa bogies	9																																																								
57410-32	Drehgestellbl. + Abdeckung	Bogie valance + housing	Cache pour bogie + capotage	Carrelli con copertura	Tapa bogies + tapa completa	9																																																								
57410-14	Kupplungshalter	Coupling hook	Support d'attelage	Gancio	Soporte de enganche	6																																																								
57410-15	Puffer (2 Stck.)	Buffers (set of 2)	Tampons (2 unités)	Respingente (2 pezzi)	Topera (2 u.)	6																																																								
57410-50	Getriebe, komplett DC	Gearbox, complete	Engrenage, complet	Ingranaggi completi DC	Engranaje completo CC	12																																																								
57924-53	Radsatz bedr. o. Haftr. (2 Stck.)	Wheelset (set of 2)	Essieux (2 unités)	Ruote senza anelli di aderenza (2 pezzi)	Eje impreso sin aros de adherencia (2u.)	9																																																								
57410-60	Getriebe, + Abdeckung kompl	Gearbox, complete w housing	Engrenage, complet avec capot	Ingranaggi completi con copertura	Engranaje + tapa completa CC	12																																																								
57924-63	Radsatz, bedr. + Haftreifen (2 Stck.)	Wheelset (set of 2) + friction tyres	Essieux (2 unités) avec bandages	Ruote con anelli di aderenza (2 pezzi)	Eje impreso con aros de adherencia (2u.)	9																																																								
52500-71	Leiterplatte	PCB	Circuit imprimé	Circuito stampato	Circuito impreso	10																																																								
<table border="1"> <thead> <tr> <th></th> <th>Ersatzteile aus unserem Standard-Programm</th> <th>Spare parts standard range</th> <th>Pièces détachées de notre programme standard</th> <th>Pezzi di ricambio standard</th> <th>Repuestos de nuestro programa standard</th> <th></th> </tr> </thead> <tbody> <tr> <td>56028</td> <td>Haftreifen (10 Stck.)</td> <td>Traction Tyres (set of 10)</td> <td>Bandage (10 unités)</td> <td>Anelli di aderenza (10 pezzi)</td> <td>Aros de adherencia (10 u.)</td> <td></td> </tr> <tr> <td>56030</td> <td>Kupplung, vollst. (2 Stck.)</td> <td>Coupling, complete (set of 2)</td> <td>Attelage, complet (2 unités)</td> <td>Ganci completi (2 pezzi)</td> <td>Enganche completo (2 u.)</td> <td></td> </tr> <tr> <td>56090</td> <td>Glühlampe (2 Stck.)</td> <td>Light bulbs (set of 2)</td> <td>Ampoule à incandescence (2 unités)</td> <td>Lampadine ad incandescenza (2 pezzi)</td> <td>Lámparas (2 u.)</td> <td></td> </tr> <tr> <td>56122</td> <td>Multiprotokolldecoder Hobby mit Lastregelung (DC/AC)</td> <td>Multi protocol decoder Hobby with load regulator (DC/AC)</td> <td>Décodeur à protocoles multiples Hobby et régulation de charge</td> <td>Multi protocollo HOBBY con regolatore di carico (DC/AC)</td> <td>Decoder multiprotocolo Hobby con regulación de carga (CC/CA)</td> <td></td> </tr> <tr> <td>56129</td> <td>Brückenstecker</td> <td>DC Bridge</td> <td>Pontage à enficher</td> <td>Ponte</td> <td>Puente</td> <td></td> </tr> <tr> <td>56156-2</td> <td>Stromabnehmer</td> <td>Pantograph</td> <td>Pendule-étrier de la caténaire</td> <td>Pantografi</td> <td>Pantógrafo</td> <td></td> </tr> <tr> <td>56503</td> <td>PIKO SmartDecoder 5.1 8polig</td> <td>PIKO SmartDecoder 5.1 8-pole</td> <td>PIKO SmartDécodeur 5.1 8 pôles</td> <td>PIKO SmartDecoder 5.1 8 poli</td> <td>PIKO SmartDecoder 5.1 8 polos</td> <td></td> </tr> </tbody> </table>								Ersatzteile aus unserem Standard-Programm	Spare parts standard range	Pièces détachées de notre programme standard	Pezzi di ricambio standard	Repuestos de nuestro programa standard		56028	Haftreifen (10 Stck.)	Traction Tyres (set of 10)	Bandage (10 unités)	Anelli di aderenza (10 pezzi)	Aros de adherencia (10 u.)		56030	Kupplung, vollst. (2 Stck.)	Coupling, complete (set of 2)	Attelage, complet (2 unités)	Ganci completi (2 pezzi)	Enganche completo (2 u.)		56090	Glühlampe (2 Stck.)	Light bulbs (set of 2)	Ampoule à incandescence (2 unités)	Lampadine ad incandescenza (2 pezzi)	Lámparas (2 u.)		56122	Multiprotokolldecoder Hobby mit Lastregelung (DC/AC)	Multi protocol decoder Hobby with load regulator (DC/AC)	Décodeur à protocoles multiples Hobby et régulation de charge	Multi protocollo HOBBY con regolatore di carico (DC/AC)	Decoder multiprotocolo Hobby con regulación de carga (CC/CA)		56129	Brückenstecker	DC Bridge	Pontage à enficher	Ponte	Puente		56156-2	Stromabnehmer	Pantograph	Pendule-étrier de la caténaire	Pantografi	Pantógrafo		56503	PIKO SmartDecoder 5.1 8polig	PIKO SmartDecoder 5.1 8-pole	PIKO SmartDécodeur 5.1 8 pôles	PIKO SmartDecoder 5.1 8 poli	PIKO SmartDecoder 5.1 8 polos	
	Ersatzteile aus unserem Standard-Programm	Spare parts standard range	Pièces détachées de notre programme standard	Pezzi di ricambio standard	Repuestos de nuestro programa standard																																																									
56028	Haftreifen (10 Stck.)	Traction Tyres (set of 10)	Bandage (10 unités)	Anelli di aderenza (10 pezzi)	Aros de adherencia (10 u.)																																																									
56030	Kupplung, vollst. (2 Stck.)	Coupling, complete (set of 2)	Attelage, complet (2 unités)	Ganci completi (2 pezzi)	Enganche completo (2 u.)																																																									
56090	Glühlampe (2 Stck.)	Light bulbs (set of 2)	Ampoule à incandescence (2 unités)	Lampadine ad incandescenza (2 pezzi)	Lámparas (2 u.)																																																									
56122	Multiprotokolldecoder Hobby mit Lastregelung (DC/AC)	Multi protocol decoder Hobby with load regulator (DC/AC)	Décodeur à protocoles multiples Hobby et régulation de charge	Multi protocollo HOBBY con regolatore di carico (DC/AC)	Decoder multiprotocolo Hobby con regulación de carga (CC/CA)																																																									
56129	Brückenstecker	DC Bridge	Pontage à enficher	Ponte	Puente																																																									
56156-2	Stromabnehmer	Pantograph	Pendule-étrier de la caténaire	Pantografi	Pantógrafo																																																									
56503	PIKO SmartDecoder 5.1 8polig	PIKO SmartDecoder 5.1 8-pole	PIKO SmartDécodeur 5.1 8 pôles	PIKO SmartDecoder 5.1 8 poli	PIKO SmartDecoder 5.1 8 polos																																																									

*Preisgruppe *price category *catégorie de prix *Categoría prezzi *Grupo de precio

Bei Ersatzteilanforderung bitte immer die vollständige Ersatzteil-Nr. angeben. · Please order the wanted spare part with the complete spare part item number.
Pour commander des pièces de rechange, ne pas oublier de donner le Numéro d'Article de la pièce demandée. · 订购配件时请附上完整的配件号码。

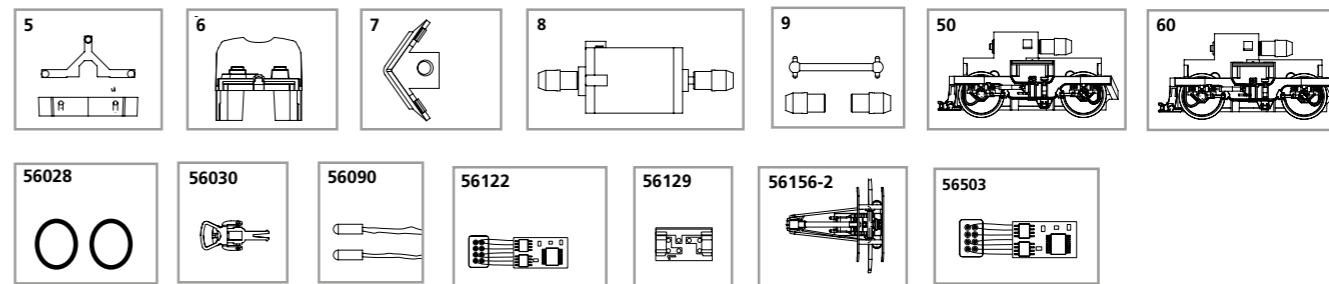

ET-Nr.	说明:	Beschrijving:	Oznaczenie:	Описание:	Opis:	PG*																																																								
57926-01	已装饰车身+车窗	Behuizing, gedecoreerd+vensters	Obudowa z oknami	Корпус и окна	Karoserie, potíštěná s okny	13																																																								
57410-02	绝缘器/屋顶线	Isolatoren / dakleidingen	Izolatory / przewody dachowe	изоляторы и оборудования	Isolatory / Sřešní vedení	8																																																								
57922-03	车顶	Dak, compleet	Dach, kompletny	Верхняя панель	Střecha, úplná	9																																																								
57410-05	导光柱	Lichtgeleider	Światłowód	Световоды	Světlovody	6																																																								
57410-06	内部装置	Binneninrichting	Wyposażenie wnętrza	Интерьер кабины и машинист	Vnitřní zařízení	7																																																								
57410-07	雪铲	Sneeuwschuiver	Odśnieżacz	Путичиститель	Pluh	7																																																								
57410-08	马达组件	Motor, compleet	Silnik, komplet	Двигатель с муфтами	Motor, komplet	12																																																								
57410-09	球轴 + 接头	Cardanaandrijving, 3-delig	Napęd Kardana, 3-częściowy	Кардан с муфтами	Kardan + pouzdra	7																																																								
57410-11	夹子	Klemmetje	Klamra	Фиксатор тележки	Třmen	6																																																								
57410-12	轮架	Draaistelzijde	Oslona wózka wagonu	Корпус тележки	Číslo masky podvozku s točnou	9																																																								
57410-32	轮架 + 轮架盖	Draaistelzijde + afdekking	Oslona wózka wagonu + przykrywka	Корпус тележки	Číslo masky podvozku s točnou + kryt	9																																																								
57410-14	挂钩	Koppelingshouder	Uchwyt sprzęgla	Держатель сцепки	Držák spřáhla	6																																																								
57410-15	泵把 (2套)	Buffer (2 stuks)	Bufor (2 szt.)	Буфера (2 шт.)	Nárazník (2 ks)	6																																																								
57410-50	齿轮箱	Aandrijving, compleet	Przekładnia, kompletna	Тележка в сборе	Převodovka, kompletní	12																																																								
57924-53	轮子组件 (2套)	Wielstel (2 stuks)	Komplet kół (2 szt.)	Колёсные пары (2 шт.)	Sada dvojkolí (2 ks)	9																																																								
57410-60	带盖齿轮箱	Aandrijving, compl. m. afdekking	Przekładnia, kompletna z przykrywką	Тележка в сборе DC	Převodovka kompletní s krytem	12																																																								
57924-63	防滑轮组 (2套)	Wielstel (2 stuks) + antislipbanden	Komplet kół (2 szt.) + opony scierne	Колёсные пары (2 шт.) + с бандажами	Sada dvojkolí (2 ks) s bandáže kol	9																																																								
52500-71	PCB主板	Printplaa	Płytko do podłączenia dekodera	Плата для подключения декодера	Rozvodná destička	10																																																								
<table border="1"> <thead> <tr> <th></th> <th>备用零件的标准范围:</th> <th>Reserveonderdelen uit ons standaard leveringsprogramma</th> <th>Części zamienne z programu standardowego</th> <th>Запасные части из стандартной программы</th> <th>Náhradní díly z našeho standardního programu</th> <th></th> </tr> </thead> <tbody> <tr> <td>56028</td> <td>防滑胶胎 (10个)</td> <td>Antislipbanden (10 stuks)</td> <td>Obreze przyczepnościowe (10 szt.)</td> <td>Колёсные бандажи (10 шт.)</td> <td>Upevnění kol (10 ks)</td> <td></td> </tr> <tr> <td>56030</td> <td>挂钩组件 (2套)</td> <td>Koppeling, volledig (2 stuks)</td> <td>Sprzęgło, kompletne (2 szt.)</td> <td>Сцепки (2 шт.)</td> <td>Spřáhlo komplet (2 ks)</td> <td></td> </tr> <tr> <td>56090</td> <td>灯泡 (2套)</td> <td>Gloeilamp (2 stuks)</td> <td>Žarówka (2 szt.)</td> <td>Лампы (2 шт.)</td> <td>Osvětlení (2 ks)</td> <td></td> </tr> <tr> <td>56122</td> <td>Hobby解码器 (DC/AC)</td> <td>Multiprotocol locdecoder Hobby-met snelheidsregeling</td> <td>Wielofunkcyjny dekodery Hobby z regulacją ładowania (DC/AC)</td> <td>Мультипротокольный декодер Hobby с регулированием работы (DC/AC)</td> <td>Multiplichační protokolový dekodér Hobby regulaci zatížení (DC/AC)</td> <td></td> </tr> <tr> <td>56129</td> <td>插板</td> <td>Overbruggingsstekker</td> <td>Wtyczka do podłączenia dekodera</td> <td>Заглушка на разъем под декодер</td> <td>Můstková zástrčka</td> <td></td> </tr> <tr> <td>56156-2</td> <td>天线架</td> <td>Pantograaf</td> <td>Pałak trakcyjny</td> <td>Пантограф</td> <td>Vrchní sběračové vedení</td> <td></td> </tr> <tr> <td>56503</td> <td>PIKO智能解码器5.1 8针</td> <td>PIKO SmartDecoder 5.1 8-polig</td> <td>PIKO SmartDekoder 5.1 8-biegunowy</td> <td>PIKO Smartдекодер 5.1 8-контактный</td> <td>PIKO SmartDekoder 5.1 8 pinů</td> <td></td> </tr> </tbody> </table>								备用零件的标准范围:	Reserveonderdelen uit ons standaard leveringsprogramma	Części zamienne z programu standardowego	Запасные части из стандартной программы	Náhradní díly z našeho standardního programu		56028	防滑胶胎 (10个)	Antislipbanden (10 stuks)	Obreze przyczepnościowe (10 szt.)	Колёсные бандажи (10 шт.)	Upevnění kol (10 ks)		56030	挂钩组件 (2套)	Koppeling, volledig (2 stuks)	Sprzęgło, kompletne (2 szt.)	Сцепки (2 шт.)	Spřáhlo komplet (2 ks)		56090	灯泡 (2套)	Gloeilamp (2 stuks)	Žarówka (2 szt.)	Лампы (2 шт.)	Osvětlení (2 ks)		56122	Hobby解码器 (DC/AC)	Multiprotocol locdecoder Hobby-met snelheidsregeling	Wielofunkcyjny dekodery Hobby z regulacją ładowania (DC/AC)	Мультипротокольный декодер Hobby с регулированием работы (DC/AC)	Multiplichační protokolový dekodér Hobby regulaci zatížení (DC/AC)		56129	插板	Overbruggingsstekker	Wtyczka do podłączenia dekodera	Заглушка на разъем под декодер	Můstková zástrčka		56156-2	天线架	Pantograaf	Pałak trakcyjny	Пантограф	Vrchní sběračové vedení		56503	PIKO智能解码器5.1 8针	PIKO SmartDecoder 5.1 8-polig	PIKO SmartDekoder 5.1 8-biegunowy	PIKO Smartдекодер 5.1 8-контактный	PIKO SmartDekoder 5.1 8 pinů	
	备用零件的标准范围:	Reserveonderdelen uit ons standaard leveringsprogramma	Części zamienne z programu standardowego	Запасные части из стандартной программы	Náhradní díly z našeho standardního programu																																																									
56028	防滑胶胎 (10个)	Antislipbanden (10 stuks)	Obreze przyczepnościowe (10 szt.)	Колёсные бандажи (10 шт.)	Upevnění kol (10 ks)																																																									
56030	挂钩组件 (2套)	Koppeling, volledig (2 stuks)	Sprzęgło, kompletne (2 szt.)	Сцепки (2 шт.)	Spřáhlo komplet (2 ks)																																																									
56090	灯泡 (2套)	Gloeilamp (2 stuks)	Žarówka (2 szt.)	Лампы (2 шт.)	Osvětlení (2 ks)																																																									
56122	Hobby解码器 (DC/AC)	Multiprotocol locdecoder Hobby-met snelheidsregeling	Wielofunkcyjny dekodery Hobby z regulacją ładowania (DC/AC)	Мультипротокольный декодер Hobby с регулированием работы (DC/AC)	Multiplichační protokolový dekodér Hobby regulaci zatížení (DC/AC)																																																									
56129	插板	Overbruggingsstekker	Wtyczka do podłączenia dekodera	Заглушка на разъем под декодер	Můstková zástrčka																																																									
56156-2	天线架	Pantograaf	Pałak trakcyjny	Пантограф	Vrchní sběračové vedení																																																									
56503	PIKO智能解码器5.1 8针	PIKO SmartDecoder 5.1 8-polig	PIKO SmartDekoder 5.1 8-biegunowy	PIKO Smartдекодер 5.1 8-контактный	PIKO SmartDekoder 5.1 8 pinů																																																									

*价格表 *Priscategorie *Grupa cenowa *ценовая категория *Cenová skupina