

Soundeinbau:  
Installing Sound /  
Instalace zvukového modulu /  
安装发声部件

56342 LokSound Decoder  
56342 LocSound Decoder  
56342 Zvukový modul  
56342 解码器

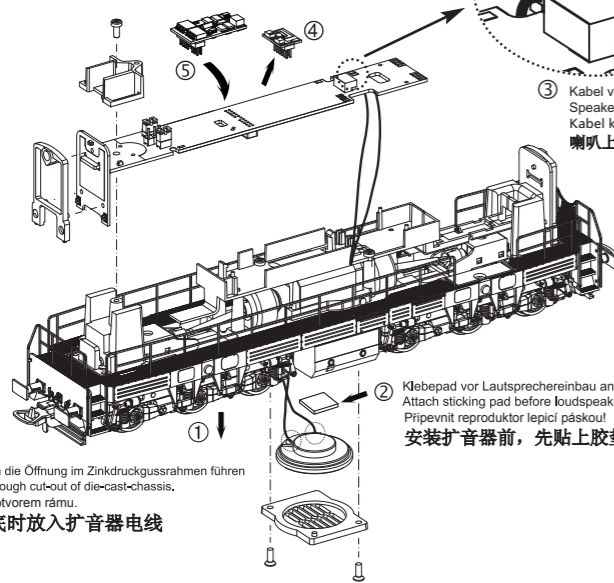

③ Kabel von Lautsprecher auf Leiterplatte anlöten!  
Speaker cable by soldering on PCB!  
Kabel k reproduktorům pájení na PCB!  
喇叭上的电线焊接到主板上!

② Klebepad vor Lautsprechereinbau anbringen!  
Attach sticking pad before loudspeaker installation!  
Pripevniť reproduktor lepiaci páskou!  
安装扩音器前，先贴上胶垫!

! Lautsprecherkabel durch die Öffnung im Zinkdruckgussrahmen führen  
Put wires for speaker through cut-out of die-cast-chassis.  
Reproduktor prostrčte otvorem rámu.  
在打开合金车底时放入扩音器电线

! Sicherstellen, dass dabei keinerlei elektrische Verbindungen zum Metallrahmen entstehen (Kurzschlussgefahr!).  
Make sure that there no electrical connection to the metal frame formed (causing a short circuit).  
Ujistěte se, že žádné elektrické připojení kovový rám tvoří (způsobující zkrat).  
注意：须确保合金车底无电流通过！（以免造成短路）

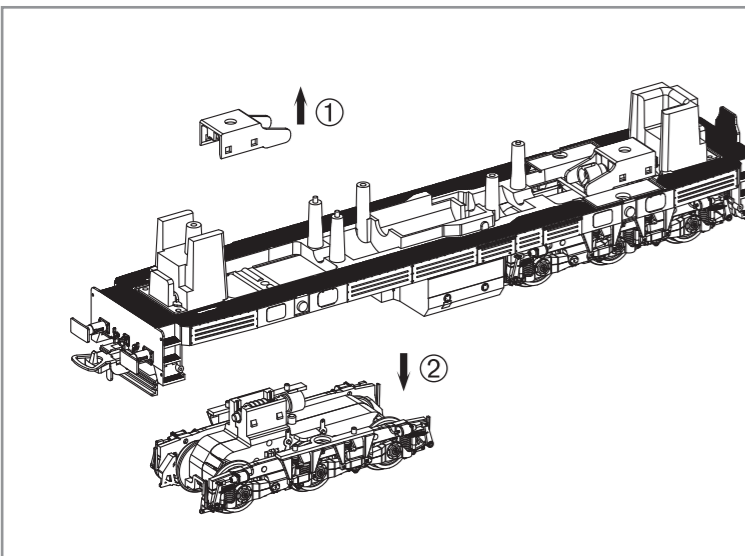
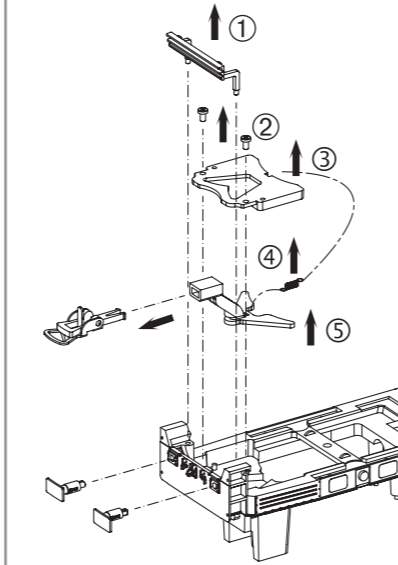

Haftreifenwechsel:  
Change the Traction Tyres /  
Výměna bandáží /  
更换胶胎

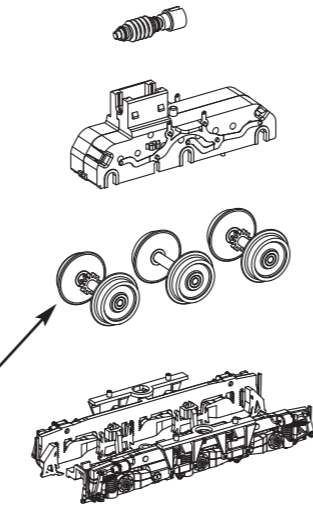

PIKO Art.-Nr.:  
#56301 Lok-Öl (50 ml)  
#56301 Loco-Oil / #56301 比高机油  
#56300 Lok-Öler mit Feindosierung  
#56300 Precision engine oiler w fine dosage / #56300 比高机油



Ölen Sie bei häufigem Fahrbetrieb die Achslager mit einem Tropfen harz- und säurefreiem Nähmaschinenöl! Wir empfehlen, die Lok ca. 25 min je Fahrtrichtung ohne Belastung einlaufen zu lassen, damit das Modell einen optimalen Rundlauf und eine gute Zugkraft erhält. Bitte beachten Sie, daß der einwandfreie Lauf des Modells nur auf sauberen Schienen gewährleistet ist.

If used frequently, oil the wheelsets with a drop of non-resinous, acid-free sewing machine oil! In order to achieve the best possible running and traction properties, it is advisable to run the locomotive in for 25 minutes forwards and 25 minutes in reverse without load. Clean rails are essential for good performance.

Pro mazání ložisek dvojkolí použijte kapku oleje na šici stroje bez obsahu kyselin a pryskyřice!  
Doporučujeme nechat jezdit model cca 25 mm bez zátěže, aby byly zaručeny optimální provozní vlastnosti. Nezapomeňte, že provoz modelu vyžaduje čisté kolejnice.

En cas d'utilisation intense, graisse les essieux avec une goutte d'huile pour machine à coudre exempte d'acide ou de résine! Afin d'optimiser les caractéristiques de traction et de fonctionnement, il est recommandé de faire rouler la locomotive seule, sans chargement, 25 minutes dans chaque sens. Pour un bon fonctionnement, il est essentiel que la voie soit propre.

Se usate frequentemente l'olio, per il set delle ruote, mettete una goccia di olio, quello utilizzato nella macchina da cucire.

如果经常使用，可以在车轮上加上不含树脂、非酸性机油！我们建议，让此火车不断转换方向地行驶大约25分钟，以便让它保持最优的回转及良好的牵引力。请注意，只有在清洁的轨道上才能保证此模型行驶顺畅。

Si está sometida a un uso intensivo, engrase los ejes con una gota de aceite de maquina no acido.

Breng, bij regelmatig gebruik, op de wagenassen een druppeltje hars- en zuurvrije naaimachineolie aan!

W przypadku częstego używania należy wpuścić kroplę oleju maszynowego nie zawierającego żywic i kwasu!

При частом использовании необходимо смазывать колесные механизмы маслом для швейных машин. Для того, чтобы достичь наилучшей тяги и качества движения состава, рекомендуется прогнать локомотив в течение 25 минут вперед и в течение того же времени назад. Также необходимо содержать железнодорожные пути в чистоте.

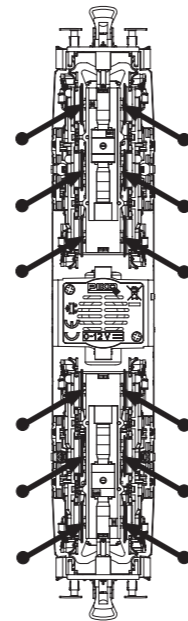

## BEDIENUNGSANLEITUNG DIESELLOK T669

Instructions for use diesel loco · Návod k obsluze T669 · Manuel d'utilisation pour locomotive diesel · Manuale d'utilizzo per la locomotiva · 柴油火车头T669的使用说明  
Manual de usuario de la locomotora · Gebruiksaanwijzing locomotief  
Instrukcja obsługi lokomotywy · Инструкция по эксплуатации Тепловоз Т669

包装及说明书内包含重要信息，请保留备用

# 59787 Gleichstrom DC

PluX22

0-12 V

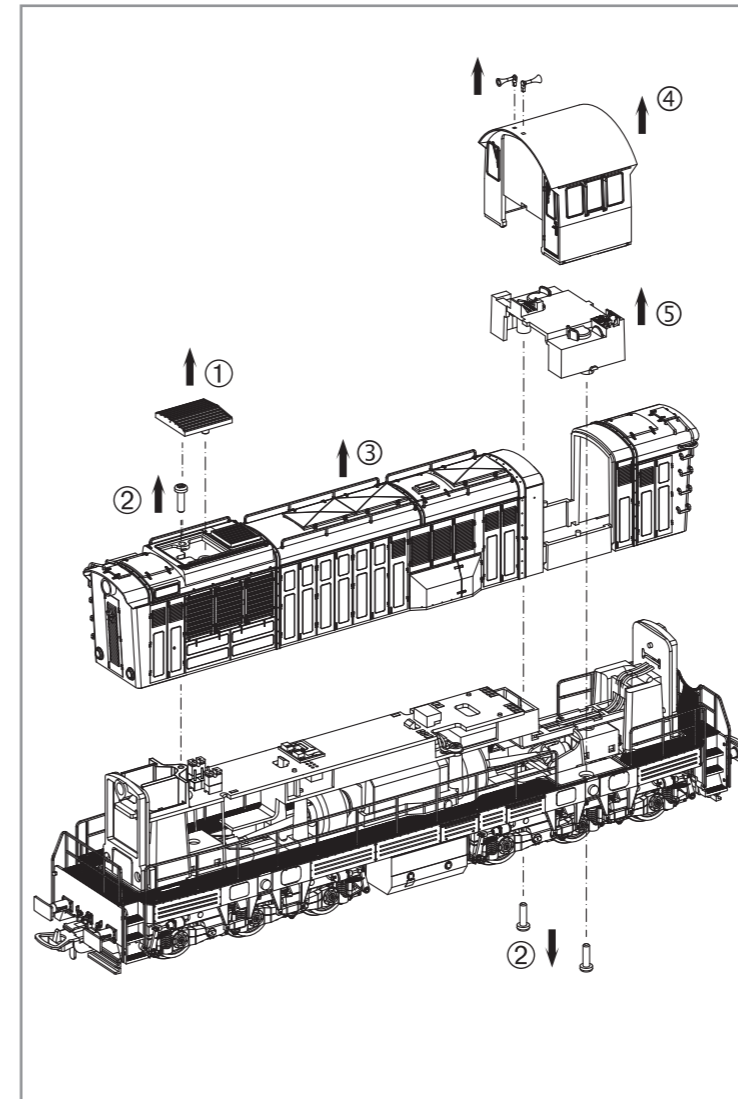

Dekodereinbau:  
Installing Decoder / Instalace dekodéru / 安装解码器

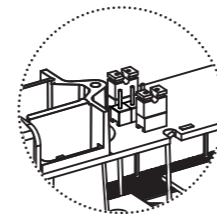

Hinweis: Schaltmöglichkeiten siehe FAQ's unter [www.piko.de](http://www.piko.de)!

Note: Switching options see FAQ below [www.piko.de](http://www.piko.de)!

Upozornění: Způsob ovládání viz FAQ pod [www.piko.de](http://www.piko.de)!

注：开关常见问题解答，参见[www.piko.de](http://www.piko.de)!

Hinweis:  
Die Funk-Entstörung der Anlage ist mit dieser Lokomotive sichergestellt, wenn der üblicherweise im Gleis-Anschlussstück eingebaute Kondensator eine Kapazität von mindestens 680 Nanofarad aufweist.

注意：  
如果安装在轨道连接部分的电容有680nF，则车头不会发生电磁干扰

Note:  
With this locomotive interference will not occur if the condenser normally fitted in the track connection section has a minimum capacity of 680 nano farads.

Nota:  
El sistema antiparasitario de la instalación está asegurado con esta locomotora si se utiliza, como es habitual, un tramo de vía de conexión con un condensador de como mínimo 680 nanofaradios.

Upozornění:  
Odrušení Vašeho kolejíště je s touto lokomotivou zajištěno, pokud má obvykle do kolejového nástavce zabudovaný kondensátor kapacitu minimálně 680 Nanofaradů.

Aanwijzing:  
De ontstoring van jouw modelspoorweg is bij het gebruik van deze locomotief gegarandeerd, wanneer de normaal gesproken in het railsaansluitstuk ingebouwd condensator een capaciteit van minimaal 680 nanofarad heeft.

Conseil:  
Cette locomotive est équipée d'un filtre anti-parasite. Un condensateur placé habituellement dans les joints des rails présente une capacité minimale de 680 nF.

Wskazówka:  
Ochrona przeciwzakłóceńowa urządzeń elektronicznych jest zapewniona w tej lokomotywie o ile kondensator wbudowany w część doprowadzającą prąd ma pojemność co najmniej 680 nF.

Nota:  
Con questa locomotiva Interferenze non occorono, se il condensatore normalmente montato nella traccia della sezione di connessione, ha un minimo di capacità di 680 nF.

Обратите:  
Для подавления радиопомех от работающего электродвигателя, в соответствии с законодательством, все модели PIKO оснащены специальным конденсатором.

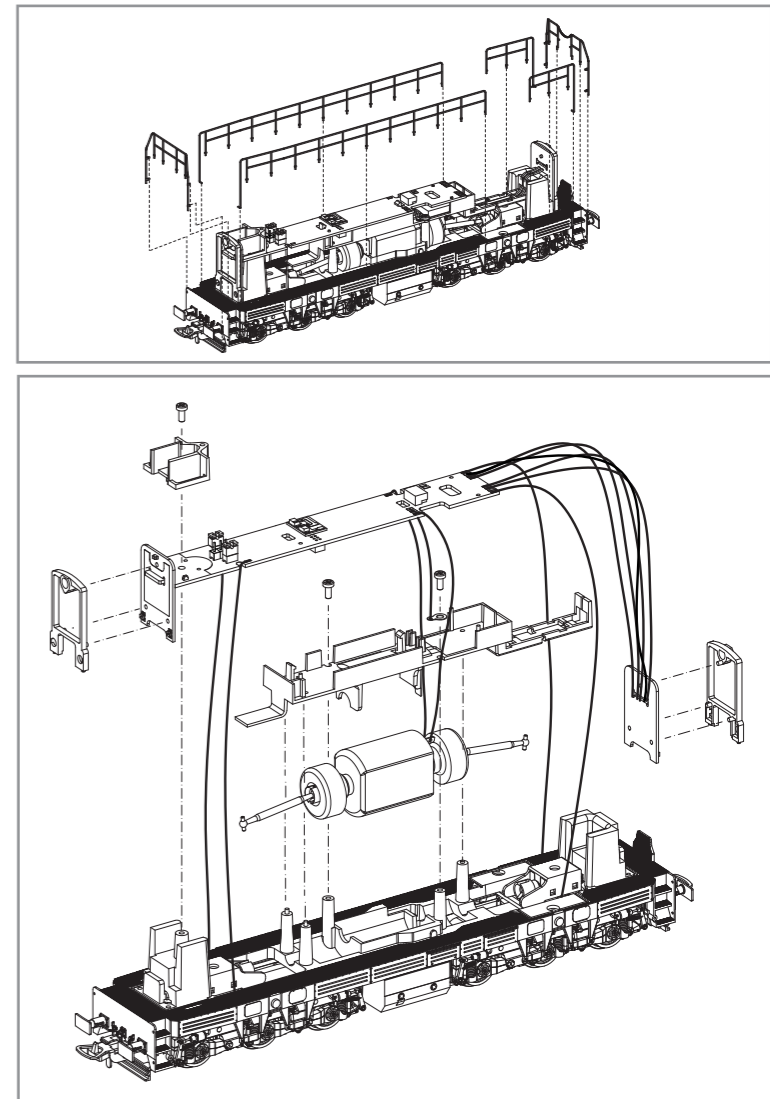

PIKO 46121 Nicht enthalten! / Not included! / Neobsahuje! / 不包括!

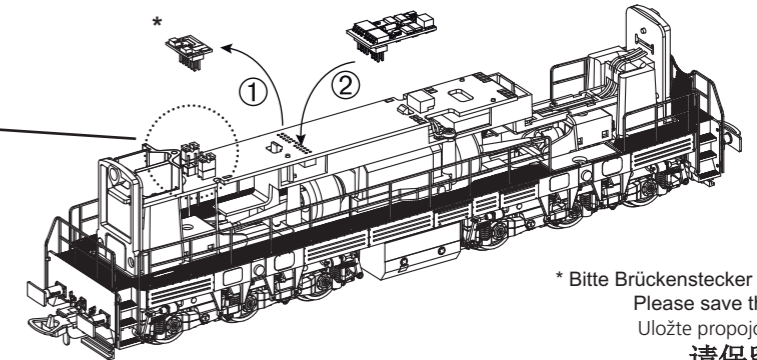

\* Bitte Brückenstecker aufbewahren!  
Please save the DC Bridge!  
Uložte propojovací destičku!  
请保留DC插板!



PIKO Spielwaren GmbH • Lutherstraße 30 • 96515 Sonneberg • GERMANY  
德国比高有限公司 • 德国图林根州索内堡市路德街30号

59787-90-7000\_V8

ERSATZTEILE DIESELLOKOMOTIVE T669

Spare parts · Náhradní díly · Pièces détachées · Parti di ricambio · 配件 · Repuestos · Reserveonderdelen · Części zamienne · Запасные части

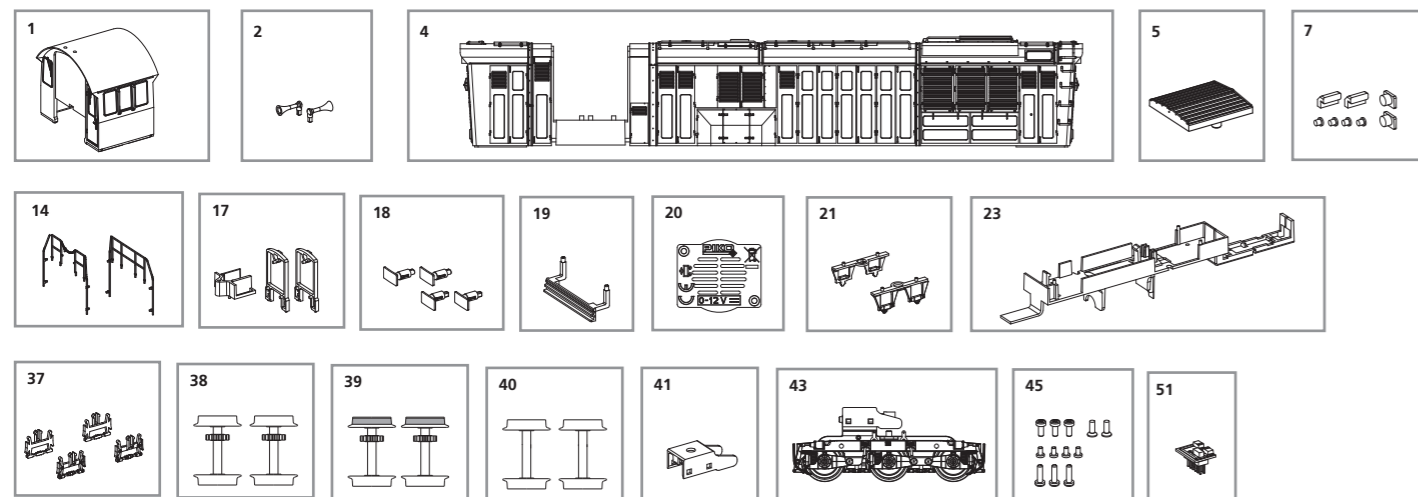

Bei Ersatzteilanforderung bitte immer die vollständige Ersatzteil-Nr. angeben. · Please order the wanted spare part with the complete spare part item number.  
Při objednávání náhradních dílů prosím uvádějte svůj plný počet. · 订购配件时请附上完整的配件号码。

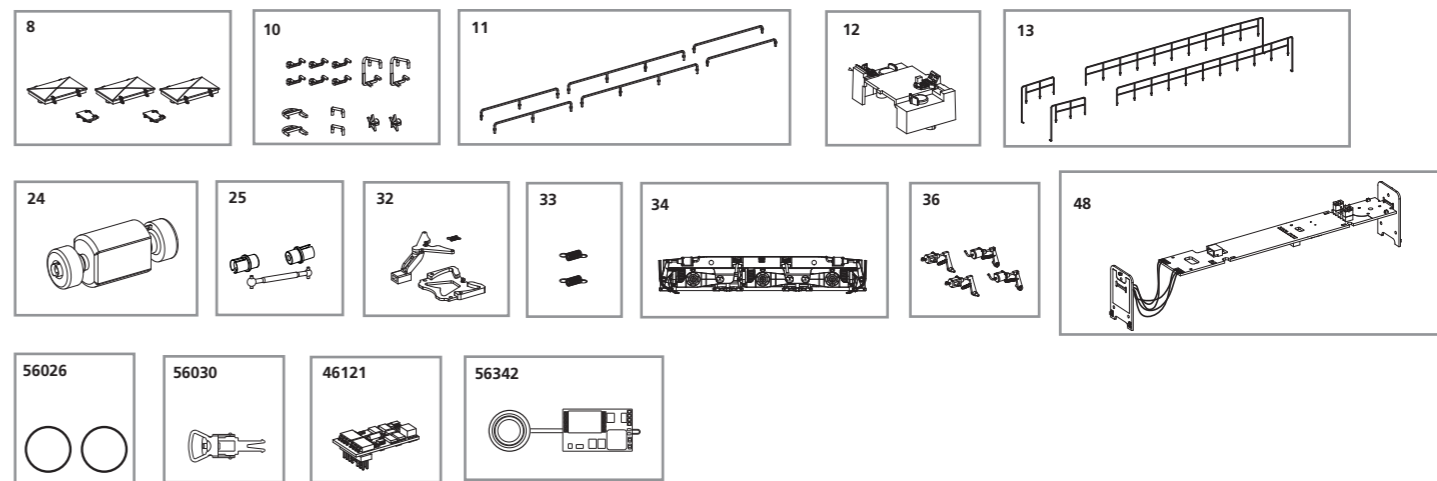

ET-Nr.:	Bezeichnung:	Description:	Popis:	Désignation:	Descrizione:	PG*																									
59787-01	Führerhaus, dekoriert (mit Fenster)	Driver's cab, decorated (with windows)	Kabina dekorovaná s okny	Cabine du conducteur, décorée (avec fenêtres)	Cabina di comando, decorato (con finestra)	11																									
59787-02	Hupe (2 Stck.)	Horn (set of 2)	Houkačka (set 2 kusy)	Klaxon (2 unité)	Tromba (2 pezzi)	6																									
59787-04	Gehäuse, dekoriert	Body, decorated	Skříň dekorovaná	Boîtier, décoré	Cassa, decorato	14																									
59787-05	Kühlerabdeckung	Radiator cover	Kryt chladiče	Couverture de radiateur	Convogliatore del radiatore	7																									
59787-07	Loknummernglas / Leuchtstab	Window number screen / Light bar	Tabulka s označením lokomotivy osvětlená	Écran du numéro de Fenêtre / barre lumineuse	Schermo numero Finestra / barra luminosa	8																									
59787-08	Deckel	Cover	Kryt	Couvrir	Coperchio	7																									
59787-10	Aufstieg / Handstange / roter Stern	Step / Handrail / red Star	Schůdky / Madla / červená hvězda	Étape / Main courante / rouge étoile	Step / Mancorrente / rosso Stella	9																									
59787-11	Handlauf Dach	Handrail Roof	Madla na střeše	Main courante toit	Mancorrente Volta	10																									
59787-12	Führerstand	Driver's cab	Stanoviště strojvedoucího	Cabine de conduite	Cabina del macchinista	7																									
59782-13	Handlauf Längsseite	Handrail on the side	Podélné zábradlí	Main courante	Mancorrente lungobordo	14																									
59782-14	Handlauf Stirnseite	Handrail front side	Čelní zábradlí	Main courante front	Mancorrente fronte	10																									
59780-17	Handtabdeckungen	Cover light	Kryt osvětlení	Paupières de phares	Coperture chiare	7																									
59780-18	Puffer (4 Stck.)	Buffer (set of 4)	Nárazníky (4kusy)	Tampon (4 unité)	Respingente (4 pezzi)	6																									
59787-19	Schienenräumer	Pilot	Štítek	Pilote	Cacciapietre	7																									
59780-20	Abdeckung Lautsprecher	Cover speaker	Kryt reproduktoru	Couverture de haut-parleur	Copertura dell'altoparlante	6																									
59780-21	Drehgestell Traverse alt (2 Stck.)	Bogie beam old (set of 2)	Podvozek traverza stará (2ks)	Bogie faisceau vieux (2 unité)	Bogie fascio vecchio (2 pezzi)	7																									
59780-23	Motorabdeckung	Cover motor	Kryt motoru	Housse de moteur	Coperchio del motore	7																									
59780-24	Motor, komplett	Motor, complete	Motor kompletní	Moteur, complet	Motore, del tutto	13																									
59780-25	Kardanwelle + Buchsen (3-tlg.)	Cardan billow + bushes (set of 3)	Kardan + pouzdro 3díly (3-tlg.)	Cardan billow + buissons (3 unité)	Albero cardanico + bussola (3 pezzi)	7																									
59780-32	Kupplungsteile (3-tlg.)	Coupling parts (set of 3)	Spřáhlo (3kusy)	Les pièces d'accouplement	Parti del giunto (3 pezzi)	8																									
59460-33	Feder für Deichsel (2 Stck.)	Spring for shaft (set of 2)	Pružina podvozku (2kusy)	Printemps de l'arbre	Molla per albero (2 pezzi)	5																									
59787-34	Drehgestell mit Bremszylinder und Bremsgestänge	Bogie with brake cylinder and brake leverage	Podvozek s brzdovými válci a brzdová táhla	Bogie avec cylindre de frein et le levier de frein	Carrello con cilindro (del) freno e leva del freno	10																									
59780-36	Bremszylinder rechts / links	Brake cylinder right / left	Brzdové válce pravý / levý	Cylindre de frein droite / gauche	cilindro (del) freno destra / sinistra	6																									
59780-37	Bremsgestänge (4 Stck.)	Brake leverage (set of 4)	Brzdová táhla (4kusy)	Levier de frein (4 unité)	Leva del freno (4 pezzi)	6																									
59780-38	Radsatz ohne Haftreifen (2 Stck.)	Wheelset w/o friction tyres (set of 2)	Dvojkolí bez bandáže (2kusy)	Essieu sans bandages (2 unité)	Sala montata senza anelli di aderenza (2 pezzi)	9																									
59780-39	Radsatz mit Haftreifen (2 Stck.)	Wheelset w friction tyres (set of 2)	Dvojkolí s bandáží (2kusy)	Essieu avec bandages (2 unité)	Sala montata con anelli di aderenza (2 pezzi)	9																									
59740-40	Radsatz ohne Zahnrad (2 Stck.)	Wheelset w/o gearwheel (set of 2)	Dvojkolí bez ozubení (2kusy)	Essieu sans roue d'engrenage (2 unité)	Sala montata senza ruota dentata (2 pezzi)	9																									
59780-41	Clip Getriebe	Clip gear box	Držák převodovky	Clip engrenage	Gancio per ingranaggio	6																									
59787-43	Getriebe	Gear box, complete	Převodovka komplet	Engrenage, complet	Ingranaggio	13																									
59780-45	Schrauben Set (12-tlg.)	Set of screw (set of 12)	Sada šroubů (12kusů)	Ensemble de vis (12 unité)	Set di vite (12 pezzi)	7																									
59784-48	Hauptplatine mit Beleuchtungsplatine und Kabel	Mainboard w light board and wires	Hlavní tištěná destička s osvětlovací destičkou a kabelem	Carte mère avec carte lumière et fils	Scheda madre con scheda di luce e cavi	16																									
59740-51	Brückenstecker	Strapping plug	Zástrčka pro přemostění	Strapping fiche	Strapping spina	8																									
<table border="1"> <thead> <tr> <th>Ersatzteile aus unserem Standard-Programm</th> <th>Spare parts standard range</th> <th>Náhradní díly z našeho standardního programu</th> <th>Pièces détachées standard</th> <th>Pezzi di ricambio standard</th> </tr> </thead> <tbody> <tr> <td>56026 Haftreifen (10 Stck.)</td> <td>Friction tyres (set of 10)</td> <td>Bandáže (10kusů)</td> <td>Bandages (10 unités)</td> <td>Anelli di aderenza (10 pezzi)</td> </tr> <tr> <td>56030 Kupplung, vollst. (2 Stck.)</td> <td>Coupling, complete (set of 2)</td> <td>Spřáhlo kompl. (2kusy)</td> <td>Boucles d'attelage (2 unités)</td> <td>Gnaci completi (2 pezzi)</td> </tr> <tr> <td>46121 Decoder PluX 16</td> <td>Decoder PluX 16</td> <td>Dekodér PluX 16</td> <td>Décodeur PluX 16</td> <td>Decoder PluX 16</td> </tr> <tr> <td>56342 PIKO Sound-Decoder</td> <td>PIKO Sound-Decoder</td> <td>Zvukový modul</td> <td>PIKO Sound-Décodeur</td> <td>PIKO Sound-Decoder</td> </tr> </tbody> </table>							Ersatzteile aus unserem Standard-Programm	Spare parts standard range	Náhradní díly z našeho standardního programu	Pièces détachées standard	Pezzi di ricambio standard	56026 Haftreifen (10 Stck.)	Friction tyres (set of 10)	Bandáže (10kusů)	Bandages (10 unités)	Anelli di aderenza (10 pezzi)	56030 Kupplung, vollst. (2 Stck.)	Coupling, complete (set of 2)	Spřáhlo kompl. (2kusy)	Boucles d'attelage (2 unités)	Gnaci completi (2 pezzi)	46121 Decoder PluX 16	Decoder PluX 16	Dekodér PluX 16	Décodeur PluX 16	Decoder PluX 16	56342 PIKO Sound-Decoder	PIKO Sound-Decoder	Zvukový modul	PIKO Sound-Décodeur	PIKO Sound-Decoder
Ersatzteile aus unserem Standard-Programm	Spare parts standard range	Náhradní díly z našeho standardního programu	Pièces détachées standard	Pezzi di ricambio standard																											
56026 Haftreifen (10 Stck.)	Friction tyres (set of 10)	Bandáže (10kusů)	Bandages (10 unités)	Anelli di aderenza (10 pezzi)																											
56030 Kupplung, vollst. (2 Stck.)	Coupling, complete (set of 2)	Spřáhlo kompl. (2kusy)	Boucles d'attelage (2 unités)	Gnaci completi (2 pezzi)																											
46121 Decoder PluX 16	Decoder PluX 16	Dekodér PluX 16	Décodeur PluX 16	Decoder PluX 16																											
56342 PIKO Sound-Decoder	PIKO Sound-Decoder	Zvukový modul	PIKO Sound-Décodeur	PIKO Sound-Decoder																											

\*Preisgruppe \*price category \*Cenová skupina \*Categorie de prix \*Categoria prezzi

ET-Nr.:	说明:	Descripción:	Omschrijving:	Opis:	Описание:	PG*																									
59787-01	驾驶室-带车窗	Cabina del conductor, decorada (con ventanas)	Bestuurderscabine, ingericht (met ramen)	Kabina, urządzone (z oknami)	Кабина машиниста (со стеклами)	11																									
59787-02	喇叭 (2个)	Bocina (2 piezas)	Horn (2 stuks)	Horn (zestaw 2)	Тепловозный гудок (2 шт)	6																									
59787-04	车身	Envase, decorado	Lichaam, versierd	Ciało, dekoracja	Корпус	14																									
59787-05	车顶散热盖	Cubierta del radiador	Radiatorkap	Oslona chłodnicy	Крышка радиатора	7																									
59787-07	车窗显示屏/导光柱	Pantalla del número de ventanas / barra de luz	Vensternummer screen / Glowstick	Okno ekran liczba / Lekki bar	Световая табличка с бортовым номером / Прожектор	8																									
59787-08	车顶盖	Cobertera	Dekken	Okladka	Крышка	7																									
59787-10	脚踏/扶手/五角星	Subida / Barandilla / estrella roja	Rise / Leuning / rode ster	Krok / poręczy / czerwony gwiazda	Ступеньки / Поручни / Красные звезды	9																									
59787-11	车顶扶手	Pasamanos techo	Dak leuning	Dach poręcz	Поручни для крыши	10																									
59780-12	操控台	Cabina de conducción	Bestuurderscabine	Kabina kierowcy	Кабине машиниста	7																									
59782-13	侧扶手	Pasamanos lateral	Leuning aan de zijkant	Poręcz po stronie	Боковые поручни	14																									
59782-14	前后扶手	Pasamanos frente	Leuning voorzijde	Poręcze przód	Передние поручни	10																									
59780-17	遮光罩	Cubierta de la luz	Cover licht	Przykryć światło	Рассеиватель света	7																									
59780-18	缓冲器 (4个)	Búfer (4 piezas)	Buffer (4 stuks)	Buffer (zestaw 4)	Буфер (4 шт)	6																									
59787-19	雪铲	Piloto	Cowcatcher	Cowcatcher	Путоочиститель	7																									
59780-20	喇叭盖	Cubierta del altavoz	Cover luidspreker	Pokrywa głośnika	Защита динамика	6																									
59780-21	轮架配件 (2个)	Bogie haz de edad (2 piezas)	Bogie beam oude (2 stuks)	Bogie belka stary (zestaw 2)	Элемент колесной тележки (траверса) (2 шт)	7																									
59780-23	马达架	Cubierta del motor	Cover motor	Pokrywa silnika	Защитный кожух двигателя	7																									
59780-24	马达组件	Motor, completar	Motor, compleet	Silnika, kompletny	Мотор	13																									
59780-25	传动杆+马达万向接头 (3个)	árbol cardán + arbustos (3 piezas)	Cardan billow + struiken (3 stuks)	Przegubowe bałwan + krzewy (zestaw 3)	Карданный вал с муфтами (набор из 3 деталей)	7																									
59780-32	挂钩组件	Piezas de acoplamiento	Koppelingsdelen (3 stuks)	Części sprzęgła (zestaw 3)	Шхота сцепки (3 деталей)	8																									
59460-33	挂钩弹簧 (2个)	Primavera para el eje	Veer voor as (2 stuks)	Wiosna na wale (zestaw 2)	Набор пружин (2 шт)	5																									
59787-34	轮架组件	Bogie con cilindro de freno y palanca de freno	Bogie met remcilinder en rem leverage	Bogie z cylindra hamulca i dźwigni hamulca	Колесная тележка с тормозными цилиндрами и рычагами	10																									
59780-36	刹车气缸 右/左	Freno cilindros derecho / izquierdo	Remcilinder rechts / links	Cylinder hamulcowy prawy / lewy	Тормозной цилиндр правый / левый	6																									
59780-37	轮架刹车片 (4个)	Palanca de freno (4 piezas)	Remstangen (4 stuks)	Dźwigni hamulcowych	Тормозной рычаг	6																									
59780-38	轮组-不带防滑胶胎	Rodaje sin aros de adherencia (2 piezas)	Wielset zonder Antislipbanden (2 stuks)	Koła bez opony przyczepnościowe (zestaw 2)	Ведущая колесная пара без антипробуксовочных резинок	9																									
59780-39	轮组-带防滑胶胎	Rodaje con aros de adherencia (2 piezas)	Wielset met Antislipbanden (2 stuks)	Koła z opony przyczepnościowe (zestaw 2)	Ведущая колесная пара с антипробуксовочными	9																									
59740-40	轮组-不带齿轮 (2个)	Rodaje sin piñón (2 piezas)	Wielset zonder versnelling	Koła bez koła zębatego	Колесная пара без шестерни	9																									
59780-41	牙箱扣	Pinza para Transmisión	Clip versnellingsbak	Klip gearbox	Держатель коробки передач	6																									
59787-43	牙箱组件	Transmisión	Versnellingsbak	Skrzynia biegów, kompletne	Коробка передач	13																									
59780-45	螺丝 (12个)	Conjunto de tornillo (12 piezas)	Set van schroef (12 stuks)	Zestaw śrub (zestaw 12)	Набор винтов (12 шт)	7																									
59784-48	主板-带电线和灯板	Mainboard con mesa de luces y cables	Moederbord met licht board en draden	Płyty główne ze światłem pokładzie i przewodów	Плата освещения с проводами	16																									
59740-51	插板	Strapping enchufe	Brugstekker	Spinania wtyczkę	Плата перемычки	8																									
<table border="1"> <thead> <tr> <th>备用零件的标准范围:</th> <th>Repuestos de nuestro programa standard</th> <th>Reserveonderdelen uit ons standaard leveringsprogramma</th> <th>Części zamienne z programu standardowego</th> <th>Базовые запасные части</th> </tr> </thead> <tbody> <tr> <td>56026 防滑胶胎 (10个)</td> <td>Aros de adherencia (10 p.)</td> <td>Antislipbanden (10 stuks)</td> <td>Opony przyczepnościowe</td> <td>Антипробуксовочные резинки</td> </tr> <tr> <td>56030 挂钩组件 (2个)</td> <td>Eganche completo (2 p.)</td> <td>Koppeling, compleet (2 st)</td> <td>Sprzęg kompletne (2 szt.)</td> <td>Сцепки в сборе (наб. 2)</td> </tr> <tr> <td>46121 16针解码器</td> <td>Decodificador PluX 16</td> <td>Decoder PluX 16</td> <td>Dekoder PluX 16</td> <td>Декодер PluX 16</td> </tr> <tr> <td>56342 带喇叭的发声组件</td> <td>PIKO LocSound Decodificador</td> <td>PIKO Sound Decoder</td> <td>PIKO Sound Dekoder</td> <td>PIKO Звуковой модуль</td> </tr> </tbody> </table>							备用零件的标准范围:	Repuestos de nuestro programa standard	Reserveonderdelen uit ons standaard leveringsprogramma	Części zamienne z programu standardowego	Базовые запасные части	56026 防滑胶胎 (10个)	Aros de adherencia (10 p.)	Antislipbanden (10 stuks)	Opony przyczepnościowe	Антипробуксовочные резинки	56030 挂钩组件 (2个)	Eganche completo (2 p.)	Koppeling, compleet (2 st)	Sprzęg kompletne (2 szt.)	Сцепки в сборе (наб. 2)	46121 16针解码器	Decodificador PluX 16	Decoder PluX 16	Dekoder PluX 16	Декодер PluX 16	56342 带喇叭的发声组件	PIKO LocSound Decodificador	PIKO Sound Decoder	PIKO Sound Dekoder	PIKO Звуковой модуль
备用零件的标准范围:	Repuestos de nuestro programa standard	Reserveonderdelen uit ons standaard leveringsprogramma	Części zamienne z programu standardowego	Базовые запасные части																											
56026 防滑胶胎 (10个)	Aros de adherencia (10 p.)	Antislipbanden (10 stuks)	Opony przyczepnościowe	Антипробуксовочные резинки																											
56030 挂钩组件 (2个)	Eganche completo (2 p.)	Koppeling, compleet (2 st)	Sprzęg kompletne (2 szt.)	Сцепки в сборе (наб. 2)																											
46121 16针解码器	Decodificador PluX 16	Decoder PluX 16	Dekoder PluX 16	Декодер PluX 16																											
56342 带喇叭的发声组件	PIKO LocSound Decodificador	PIKO Sound Decoder	PIKO Sound Dekoder	PIKO Звуковой модуль																											

\*价格表 \*Grupo de precio \*Priscategorie \*Группа ценowa \*ценовая категория